

AKKU LED HANDLEUCHE

RECHARGEABLE LED HAND LAMP

ERGOPOWER PEN+

Art. 0827 940 117

Art. 0827 940 388

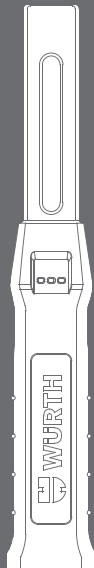

- Ⓓ Bedienungsanleitung
- ⒼⒷ Operation manual
- Ⓘ Manuale d'uso
- Ⓕ Manuel d'utilisation
- Ⓔ Manual de funcionamiento
- ⒫ Manual de funcionamento
- ⒶⒸ Bedieningshandleiding
- ⒹⓀ Brugsvejledning
- ⒸⓃ Bruksanvisning
- ⒻⒶ Käyttöohje
- ⒸⓃ Bruksanvisning
- ⒼⓇ Εγχειρίδιο λειτουργίας
- ⒻⒷ Kullanım kılavuzu
- ⒶⒻ Instrukcja użytkowania
- ⒸⓃ Kezelési útmutató
- ⒸⓅ Návod k použití
- ⒸⓀ Návod na použitie
- ⒻⒹ Manual de utilizare
- ⒸⒻⒶ Navodila za uporabo
- ⒼⒸⒹ Ръководство за експлоатация
- ⒺⒸⒶ Kasutusjuhend
- ⒻⒹ Naudojimo vadovas
- ⒻⒻ Lietošanas instrukcija
- ⒸⓇⒶ Руководство по эксплуатации
- ⒸⒻⒹ Uputstva za upotrebu
- ⒸⒻⒶ Upute za uporabu



**IK07
IP54**

Art. 0827 940 117

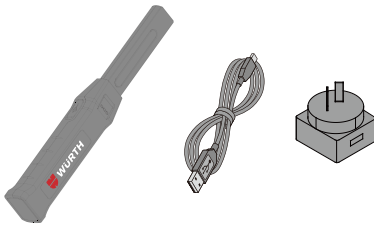
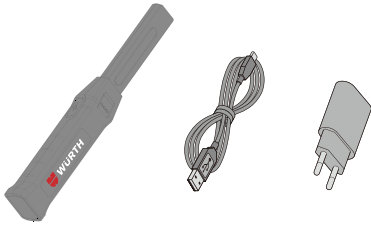

Art. 0827 940 388

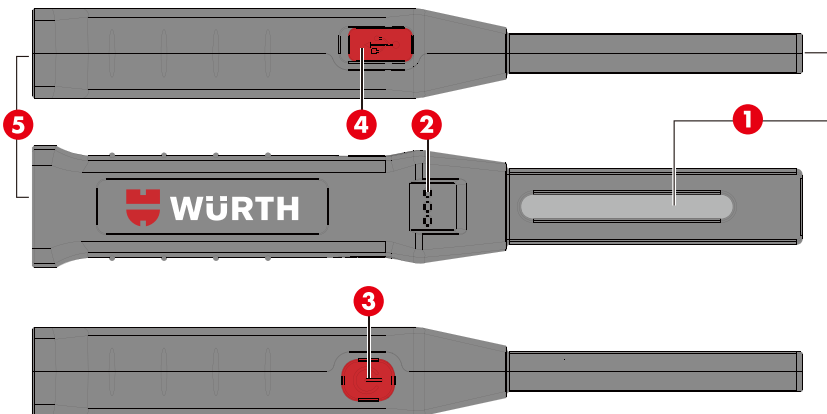
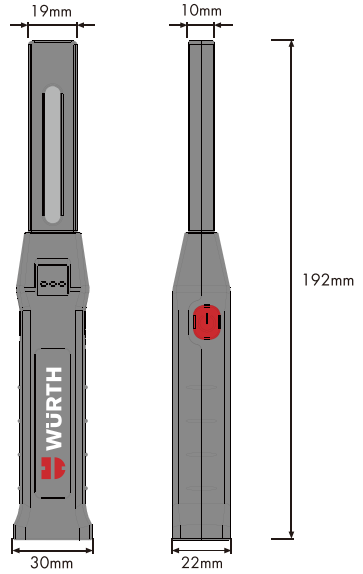

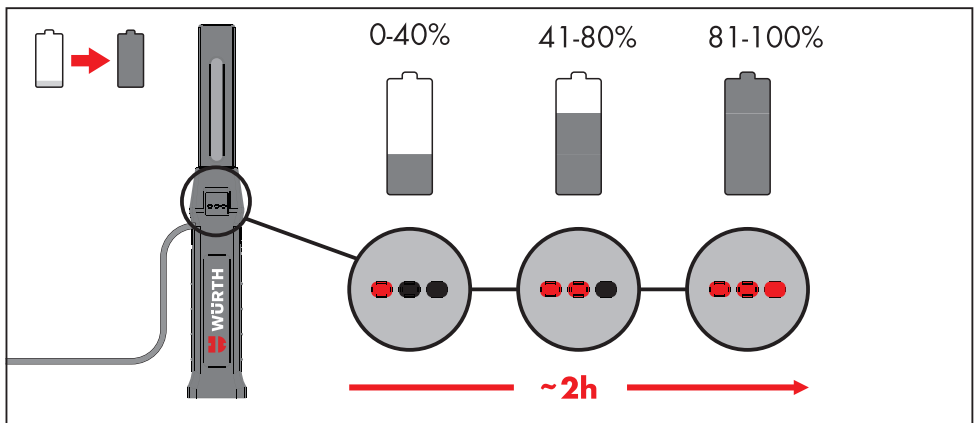
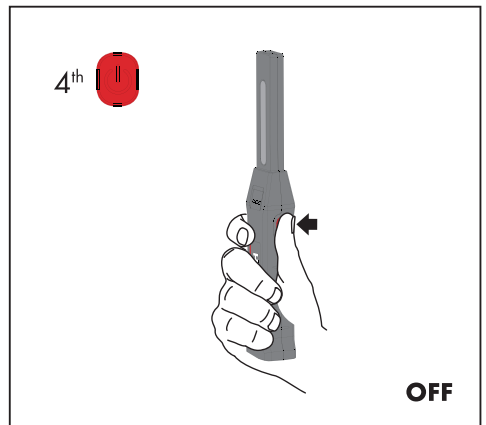
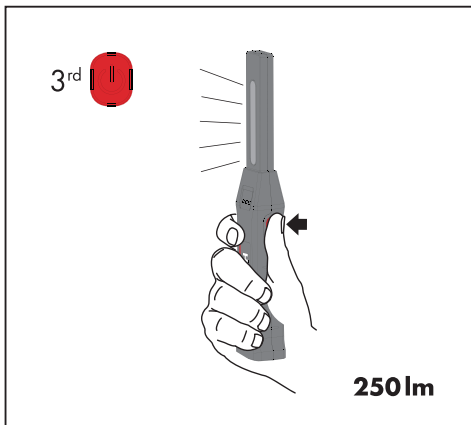
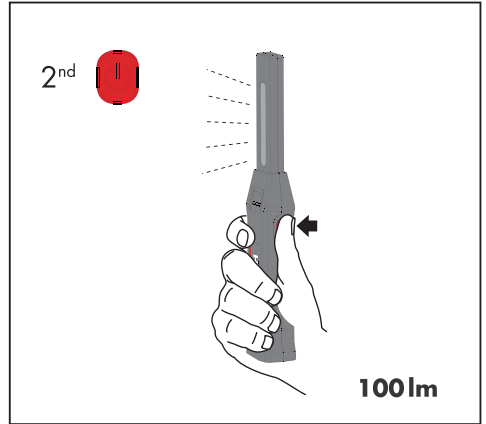
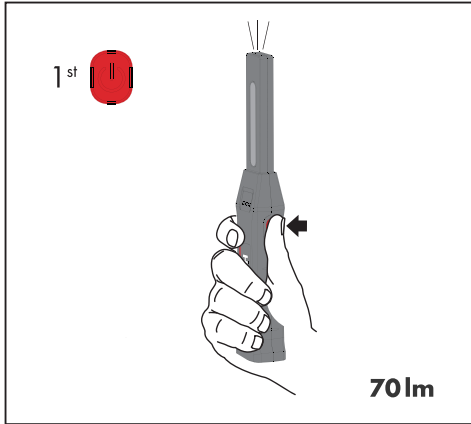

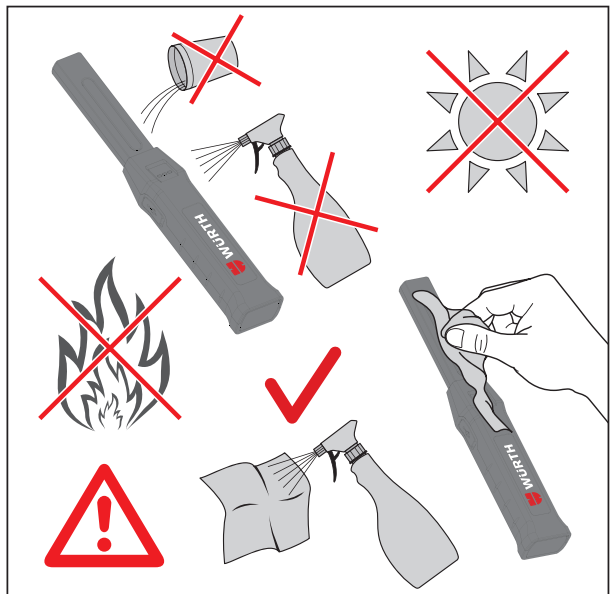
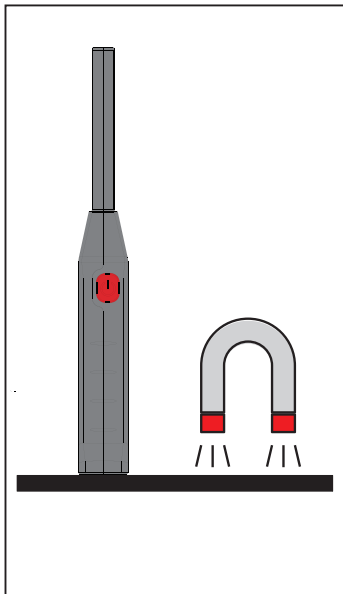
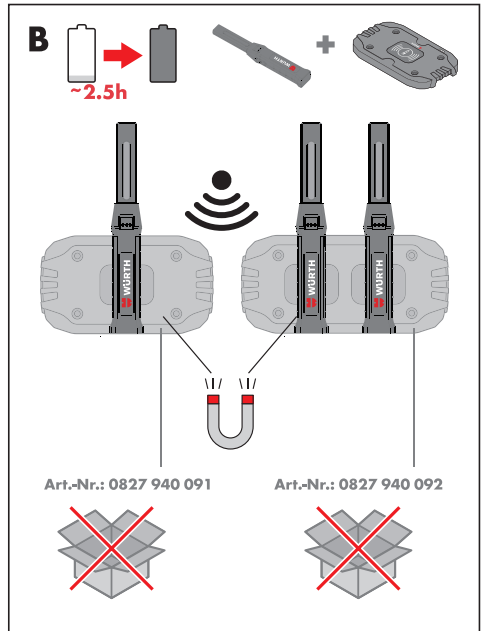
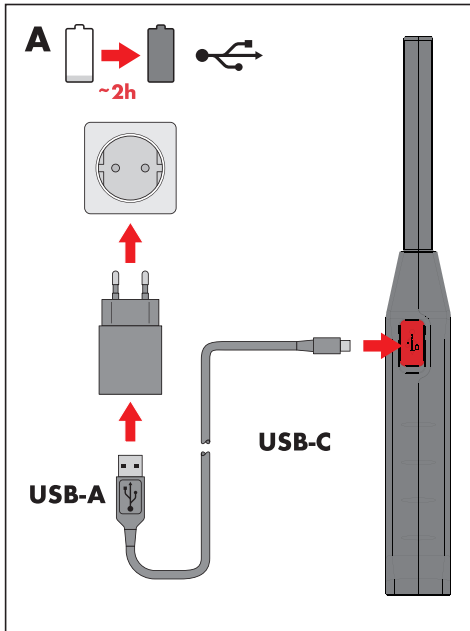

GB OPERATION MANUAL

FOR YOUR OWN SAFETY



Please read this instruction manual before using the lamp for the first time and comply with it. Keep this instruction manual for future reference or for subsequent possessors.



Warning - Do not look directly into the light emitting lamp - Risk of eye injuries!

Always only use the charger recommended by the manufacturer to charge the lamp. The use of a NON-recommended charger can lead to a fire and destroy the lamp.

USAGE

The lamp is used properly if it is only used to illuminate ordinary working areas and, in the process, complies with the specifications indicated in the technical data. Any other or additional use is not permitted.

The lamp may not be used:

- in areas with harmful gases, oils, acids, radiation, etc.
- in areas with an explosion risk.

This lamp complies with all relevant norms and standards required for CE compliance. Compliance with these standards is no longer guaranteed when this lamp has been modified.

SAFETY INSTRUCTIONS



The lamp may get hot in the vicinity of the light outlet. Therefore, maintain a distance of at least 0.1 m

- Do not open the lamp.
- There is a risk of short-circuit. Repairs on the lamp may only be carried out by commissioned and trained persons. Please contact your Würth branch.



Protect the battery against heat, e. g., against continuous intense sunlight, fire, water, and moisture. Danger of explosion.

- If the battery is damaged or not used correctly
 - vapours may leak and irritate the respiratory system. Provide fresh air and contact a doctor in the event of any discomfort.
 - fluids can leak from the battery. Avoid contact with these. Leaking battery fluids can lead to skin irritation or burns. Rinse off with water if you should come into contact. If the fluid gets into your eyes, make sure you get medical help.
 - there can be an internal short-circuit, the battery may become overheated and explode or catch fire.

A damaged lamp or a damaged charger must no longer be used: it must be replaced by the manufacturer.

- Only stand the lamp on its head when it is switched off
- The light source of this lamp cannot be exchanged. The whole lamp must be exchanged when the light source is defective.

OPERATION (SEE PAGE 2)

- 1 Light output – Spot light and main light
- 2 Battery charge status (indicator light). When switching the lamp on, the battery charge status is displayed for approx. 5 seconds.
- 3 On/Off switch:
 1. step: Spot light
 2. step: Main light 40%
 3. step: Main light 100%
- 4 USB connection – power supply and USB-cable for charging the lamp included in the delivery
- 5 Magnet

CHARGING THE BATTERY

- Before taking the hand lamp into service for the first time charge it for 6-8 hours
- Fully charge the hand lamp before it is stored for a longer period.
- Switch lamp off during charging.
- Remove the protective cap from the connector (4) and connect the cable or charger.
- Connect the power supply to the mains socket (100-240 V~).
- During charging, the indicator light (2) flashes according to the charging status.
- If charging is completed, the indicator lights (2) light up continuously.
- Do not charge the battery longer than required to prevent overheating.
- Disconnect the charger and attach the protective cap for connector (4).

NOTES REGARDING OPERATION

The switched-on lamp is very bright and the lamp may get hot in the vicinity of the light outlet. When the lamp is switched on:

- do not look directly into the light outlet.
- ensure that nobody is exposed to glare.
- do not cover the light outlet.
- do not put down the lamp with the light outlet pointing downwards.

TECHNICAL DATA

Number of LEDs	1+1, 3+1W
Battery specification	Li-Ion, 3.7 V, 1050 mAh, 3.89 Wh
Input voltage power supply unit	100-240 V AC, 50/60 Hz
Input voltage lamp	5 V DC
Current consumption of lamp	1 A
Charging time power supply unit	~2 h
Charging time charging pad	~2.5 h
Operating time main light	~1.5 - 3.5 h
Operating time spot light	4 h
LED intensity main light	250lm (100 %) / 100lm (40%)
LED intensity spot light	70lm
Service life of LED	≤ 10000 h
Degree of protection	IP54 / IK07
Storage temperature	-20 °C ... +45 °C
Operating temperature	-10 °C ... +40 °C

MAINTENANCE / CARE

Visual inspection before starting work

The lamp is maintenance-free. The lamp and its accessories must nevertheless be checked for external damage before each use.

The lamp may not be used when damage is visible. It must be repaired or disposed of by a commissioned and trained person. Please contact your Würth branch.

Cleaning

Cleaning work may only be performed when the lamp is switched off and the mains connector has been disconnected. Clean the lamp by wiping it with

a soft, clean cloth. Remove stubborn dirt with a moistened cloth and a common household cleaner. Using cleaning agents that are abrasive or contain alcohol or solvent will damage the housing.

DISPOSAL

Do not dispose of the lamp with domestic waste!



Small electrical devices and packaging must always be recycled in an environmentally appropriate manner. Electrical tools that are no longer usable must be separately collected and forwarded for environmentally appropriate recycling according to the European Directive 2012/19/EU.

WARRANTY

We offer a warranty according to the legal/state-specific regulations from the date of purchasing (proof by invoice or delivery note) for this lamp. A damaged lamp is either repaired or replaced with a substitute lamp. Damage resulting from improper handling is excluded from the warranty. Complaints can only be accepted if the lamp is handed over assembled to a Würth branch, your Würth sales representative or a Würth-authorized customer service centre.

Würth International AG
Aspermontstrasse 1
CH-7000 Chur
Switzerland
www.wurth-international.com

Würth International Trading
(Shanghai) Co., Ltd.
Capital of Leaders – Building 9
Zhangdong Road No. 1387
201203 Shanghai, P. R. China
www.wurth-international.com.cn

Würth International Trading
America, Inc.
91 Grant Street
Ramsey, NJ 07446, USA
www.wurth-international.us

Reprinting, in whole or part,
only with permission.
All rights reserved.

Editorial staff: Shirley Liu
Design staff: Susan Zhang

Corporate Design Number:
MA-2020-3959-210408 © • PAP22

Reprint only with permission:

We reserve the right to apply changes on the product without prior notice or notification if the changes apply to the improvement of quality of the product from our point of view. Illustrations may be schematic illustrations and may differ in appearance from the delivered product. We accept errors and we bear no liability for printing errors. Our general terms and conditions apply.